



## Girard™ Pressure Relief Valve For Corrosive Applications

Relieve excess pressure, that would otherwise create a hazardous condition in a tank car, safely and reliably with the Girard™ patented 407 Series pressure relief valve

### Features and Benefits:

- Body constructed of investment-cast 316L stainless steel
- ALL surfaces are Teflon® spray coated and interior wetted parts are covered with a seamless Teflon® liner
- Flow Ratings:
  - 165psi valve = 11,114 SCFM
  - 75psi valve = 8,585.9 SCFM
- Quick disassembly feature designed for ease of maintenance
- Rugged, low profile design
- Comes in standard flange styles. Other flange options available upon request
- AAR approved

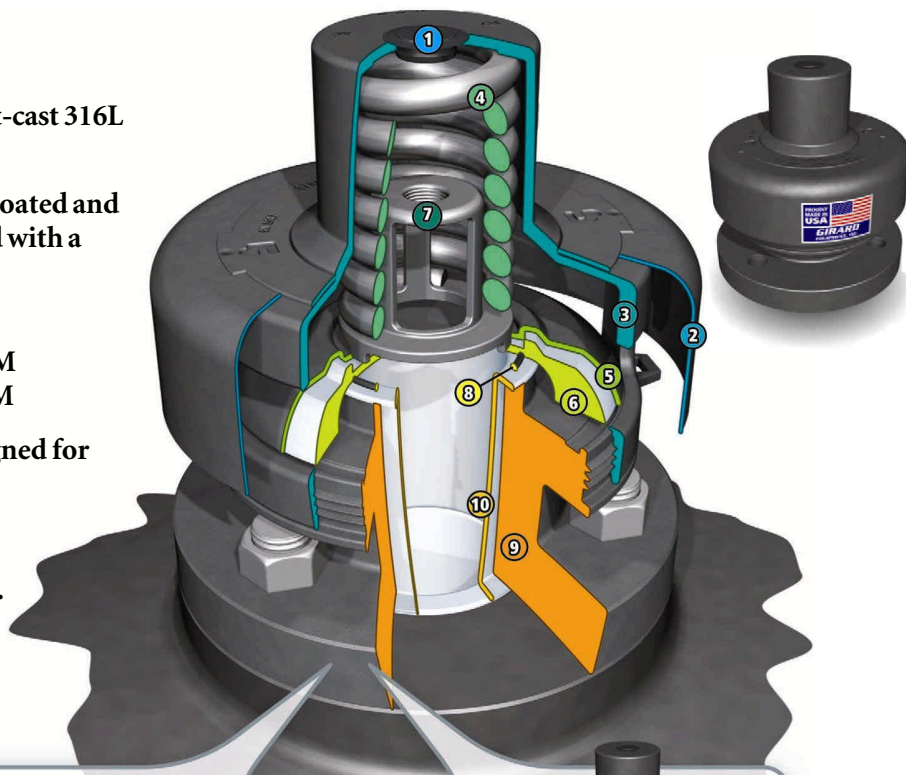

Item	Part	Name .....	Material
1	402019	Plug .....	Plastic
2	402003-TC	Rain Cover .....	Stainless Steel
3	402004-TC	Upper Housing .....	Stainless Steel
4	402005-TC	Spring .....	Stainless Steel
5	402006-TC	Poppet .....	Stainless Steel
6	402008-TC	Seat .....	Teflon®
7	GB25010-TC	Spring Retainer .....	Stainless Steel
8	402007	"O" Ring .....	Teflon® Encapsulated Silicone
9	402021-TC	Lower Housing .....	Stainless Steel
10	402021-TC	Lower Housing Line .....	Teflon®

\*-TC" designates Teflon spray-coated component.



\*Teflon® is a registered trademark of the DuPont Company

(CONTINUED ON REVERSE SIDE)

Visit our Web site at: [www.salcoproducts.com](http://www.salcoproducts.com)

# 407 Series SS Pressure Relief Vent

**RRDOT407-165-3** (3-Hole Model)  
Isometric View, 1:3 Scale

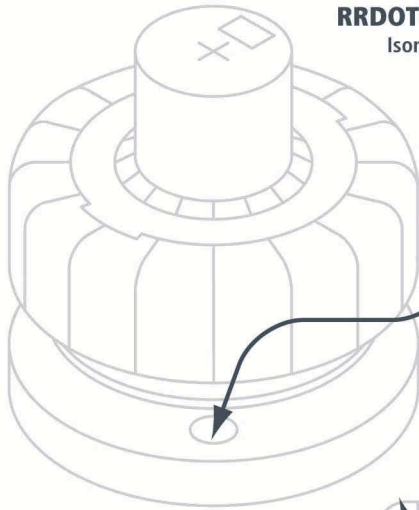

3 × ¾" holes on 5½" circle

- Upper Housing (Stainless Steel)
- Spring (Stainless Steel)
- Poppet (Stainless Steel)
- Poppet Liner (PTFE)

**RRDOT407-165-3** (3-Hole Model)  
Section View, 1:3 Scale

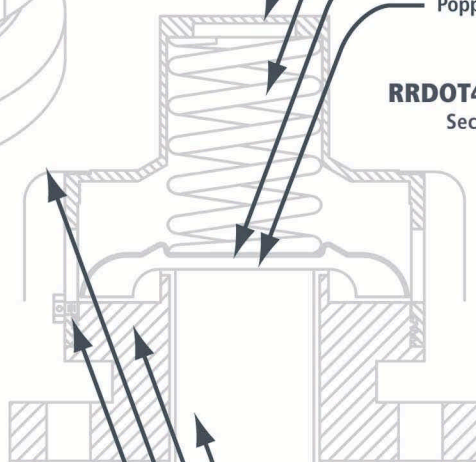

**RRDOT407-165-4** (4-Hole Model)  
Isometric View, 1:3 Scale

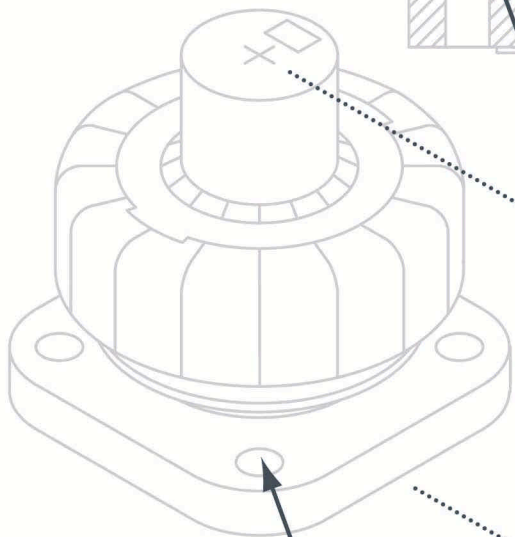

7¾"

4 × ¾" holes on 6¼" circle

- Liner (PTFE) with 4.3 in.<sup>2</sup> Opening
- Lower Housing (Stainless Steel)
- Rain Cover (Stainless Steel)
- Lockscrew With Seal Provision

*Salco is the exclusive distributor of the Girard Equipment™ 407 Series Pressure Relief Valve to the railcar marketplace*

630-783-2570  
20 W 201 101<sup>st</sup> St., Suite A  
Lemont, IL 60439

or

281-351-0274  
22311 Hufsmith-Kohrville Rd.  
Tomball, TX 77375